

EZ Series 44 G

4000 PSI, Triplex Plunger Pumps

FEATURES

- Innovative one-piece plunger design to eliminate water entering crankcase
- 5% reduction in crankcase load compared to standard 3,000 psi – 15 mm pumps
- Superior plunger performance against thermal shock and cavitation due to new, unique bonding process
- Standard SAE J609 gasoline mounting flange for up to 16 hp engines
- Forged brass manifold with an exclusive lifetime warranty and 3:1 hydrostatic rating
- Die-cast, anodized aluminum, oil-bath crankcase
- Premium roller bearing
- Unitized stainless steel inlet and discharge valves
- Available in “L” left-handed versions

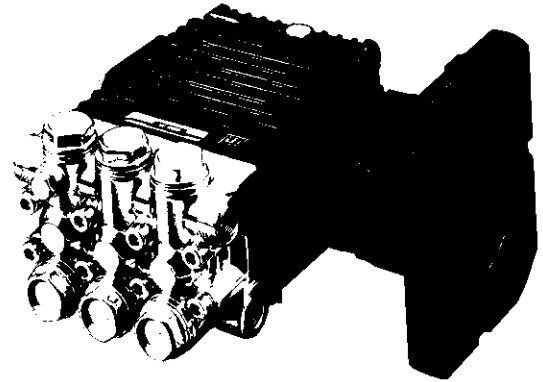

SPECIFICATIONS

Pump Model	EZ4040G34	EZ4035G34	EZ4030G34
Maximum Volume	4.0 GPM	3.5 GPM	3.0 GPM
Maximum Discharge Pressure	4000 PSI		
Maximum Pump Speed	3400 RPM		
Maximum Inlet Pressure	125 PSI		
Maximum Inlet Vacuum	Flooded		
Bore	.512 in. / 13 mm		
Stroke (in./mm)	.512 / 13	.433 / 11	.374 / 9.5
Crankcase Oil Capacity	14.0 oz.		
Maximum Fluid Temperature	165°F		
Inlet Port Thread	1/2-14 BSPP-F		
Discharge Port Thread	3/8-19 BSPP-F		
Hollow Shaft I.D.	1.0 in. / 25.4 mm		
Weight	20 lbs.		
Dimensions	8.8 x 9.7 x 6.5 in.		

EZ Series 44 G – Triplex

GENERAL PUMP *A member of the Interpump Group*

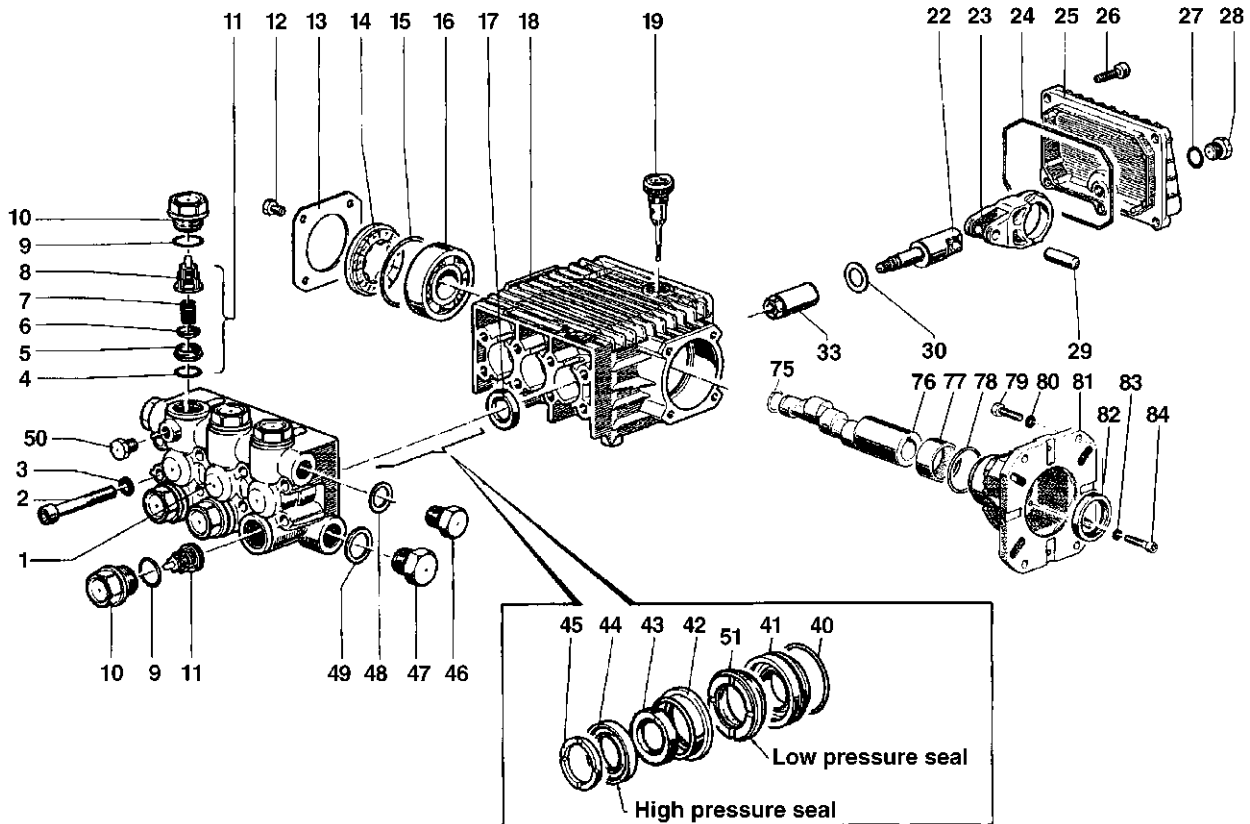

PARTS LIST

Item	Part No.	Description	Kit No.	Qty.	Item	Part No.	Description	Kit No.	Qty.	Item	Part No.	Description	Kit No.	Qty.
1.	44.1206.41	Manifold		1	22.	44.0501.66	Piston Guide		3	49.	96.7514.00	Washer		1
2.	99.3175.00	Screw		8	23.	44.0300.22	Connecting Rod		3	50.	98.1966.00	Cap Screw		1
3.	96.7014.00	Washer		8	24.	90.3920.00	O-Ring		1	51.	90.2603.00	Seal, Low Pressure	153,156	3
4.	90.3841.00	O-Ring	123	6	25.	44.1600.22	Rear Cover		1	75.	90.0635.00	Retaining Ring		1
5.	36.2003.66	Valve Seat	123	6	26.	99.1837.00	Screw		5	76.	44.0221.65	Crankshaft (EZ4040G34)		1
6.	36.2001.76	Valve	123	6	27.	90.3585.00	O-Ring		1		44.0212.65	Crankshaft (EZ4035G34)		1
7.	94.7376.00	Spring	123	6	28.	98.2041.00	Cap Screw		1		44.0209.65	Crankshaft (EZ4030G34)		1
8.	36.2025.51	Valve Cage	123	6	29.	97.7340.00	Pin		3	77.	91.8568.00	Roller Bearing		1
9.	90.3847.00	O-Ring	124	6	30.	96.6967.00	Washer		3	78.	90.4097.00	O-Ring		1
10.	98.2226.00	Cap Screw	124	6	33.	44.0402.66	Plunger, 13 mm		3	79.	99.2755.00	Screw, 5/16x1		4
11.	36.7115.01	Valve Assembly	123	6	40.	90.3612.00	O-Ring	152, 156	3		99.3345.00	Screw, 3/8x1		4
12.	99.1807.00	Screw		4	41.	44.0803.70	Packing Retainer	152, 156	3	80.	96.7020.00	Washer, Ø8 mm		4
13.	50.1500.74	Bearing Cover		1	42.	44.2162.70	Intermediate Ring	154, 156	3		96.7104.00	Washer, Ø10 mm		4
14.	44.2118.01	Spacer		1	43.	90.5076.00	Packing	153, 156	3	81.	10.0518.22	Gas Flange		1
15.	90.4097.00	O-Ring		1	44.	90.2602.00	Packing	153, 156	3	82.	90.1690.00	Oil Seal		1
16.	91.8328.00	Ball Bearing		1	45.	44.1002.51	Head Ring	155, 156	3	83.	96.6938.00	Washer		4
17.	90.1614.00	Oil Seal	23	3	46.	98.2100.00	Cap Screw		1	84.	99.1912.00	Screw		4
18.	44.0100.22	Crankcase		1	47.	98.2176.00	Cap Screw		1					
19.	98.2103.00	Oil Dip Stick		1	48.	96.7380.00	Washer		1					

REPAIR KITS

KIT NO.	23	123	124	152	153	154	156
ITEM NO'S INCLUDED IN KIT	17	4, 5, 6, 7, 8, (11)	9, 10	40, 41	43, 44, 51	42	40, 41, 42, 43, 44, 45, 51
NUMBER OF ASSEMBLIES IN KIT	3	6	6	3	3	3	1
NUMBER OF CYLINDERS KIT WILL SERVICE	3	3	3	3	3	3	1

TORQUE SPECS*

Position	Ft.-lbs.	N-M
2	14.7	20
10	73.7	100
12	7.3	10
26	7.3	10
28	14.7	20
33	6.6	9
46	29.4	40
47	29.4	40
50	9.6	13
79	14.7	20
84	7.3	10

*Decrease torque by 20% if threads are lubricated.